

Aivee

Edition one MTB

Boost Hubs

User's manual



INTRODUCTION

The range of Aivee state of the art equipments is the result of the research and development department studies supervised by a team of enthusiasts, always attentive to the needs of users. Thus, the Aivee signature is the guarantee for quality on all roads, tracks and paths.

Aivee is based on three fundamentals: emotion, innovation and accessibility. Our challenge is to encourage emotion and give pleasure to the greatest number of athletes and enthusiasts. Our goal is uncompromising, render a premium brand accessible, affordable products, leading the way to adventure !

PRESENTATION

With the Aivee Edition one MTB, we wanted to create a hub with a very simple design without neglect the strength of the hub. Edition one MTB hubs are very robust and they also have the Aivee finish. Edition one MTB hubs have watertight bearings and are lubricated with a grease specially developed for our hubs. Edition one MTB rear hubs have an increased number of engagement points, thanks to 3 pawls, they have 27 engagement points. With big size flanges, Edition one MTB are also very stiff.

The Edition one MTB range is a hub range made for MTB fanatics who search reliable equipment, with a simple design and Aivee finish.

MOUNTING

Aivee Edition one hubs are available with 28 or 32 spoke holes. The spoke tension must not exceed 1200N. Aivee Edition one MTB rear hubs are designed to work with a cassette which has a spider.

FRONT HUB

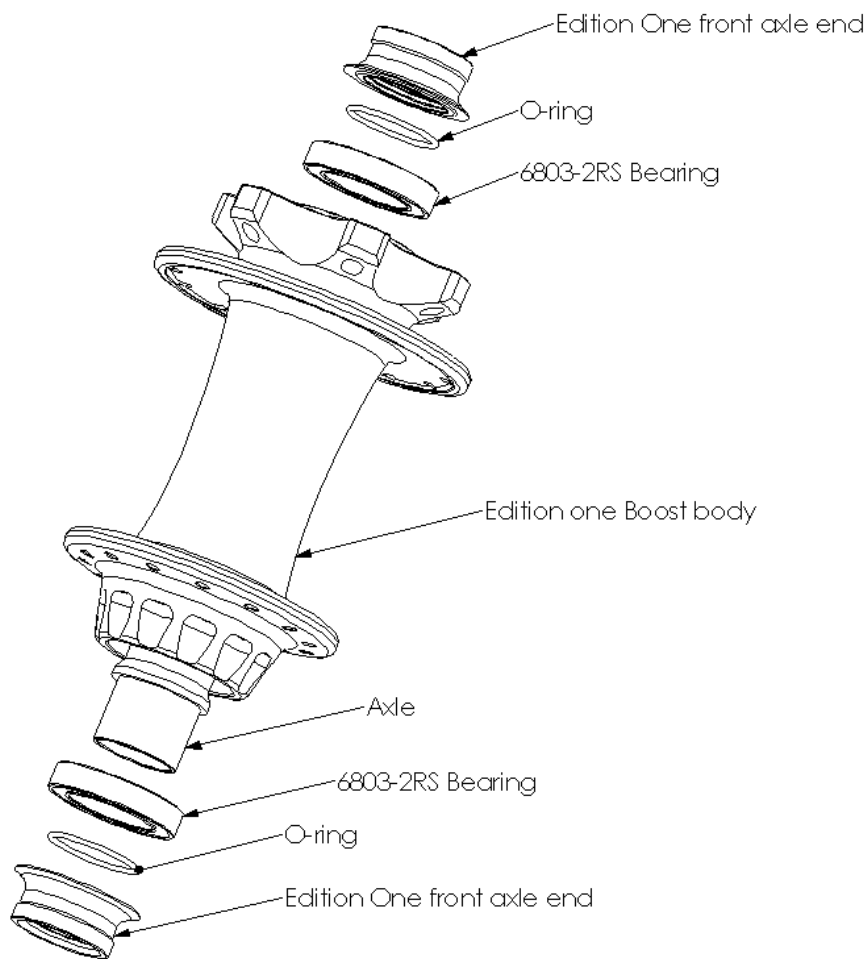

REAR HUB

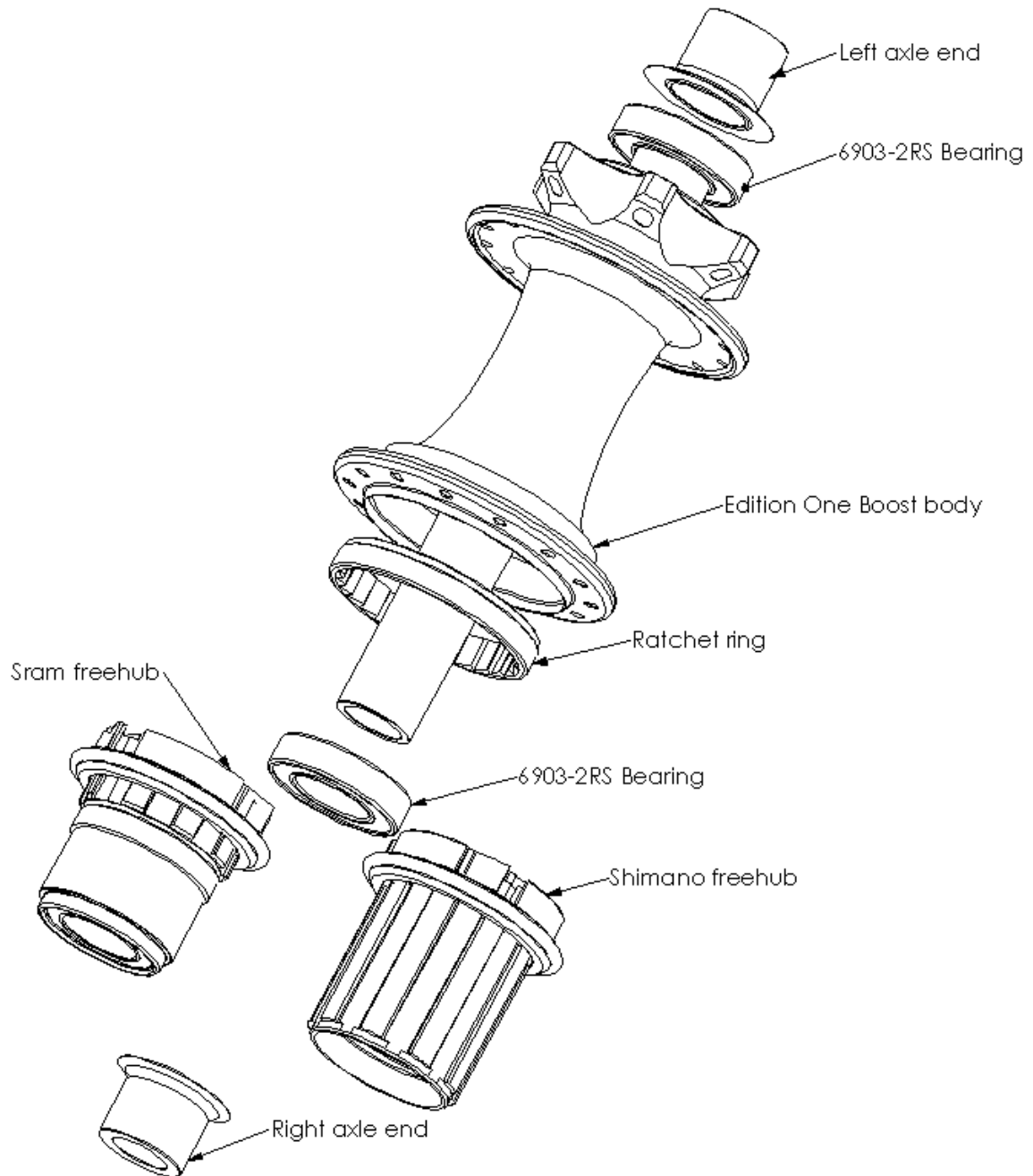

GEOMETRY / WEIGHT

Weight :

120 g

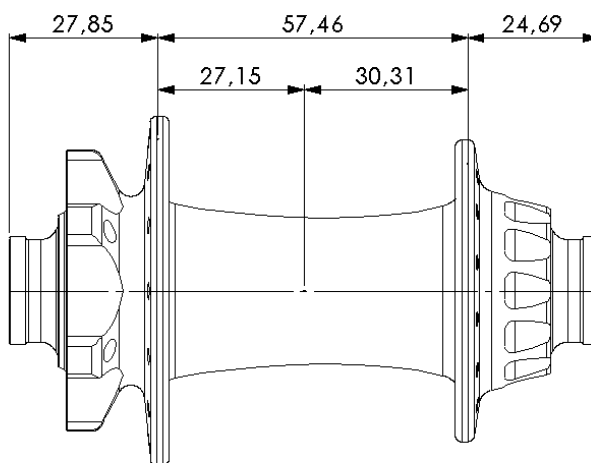
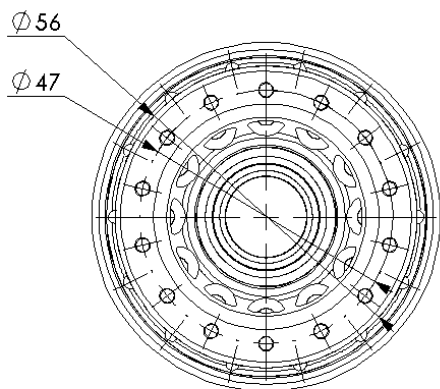

Weight :

258 g

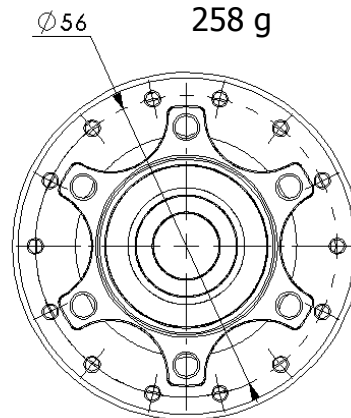
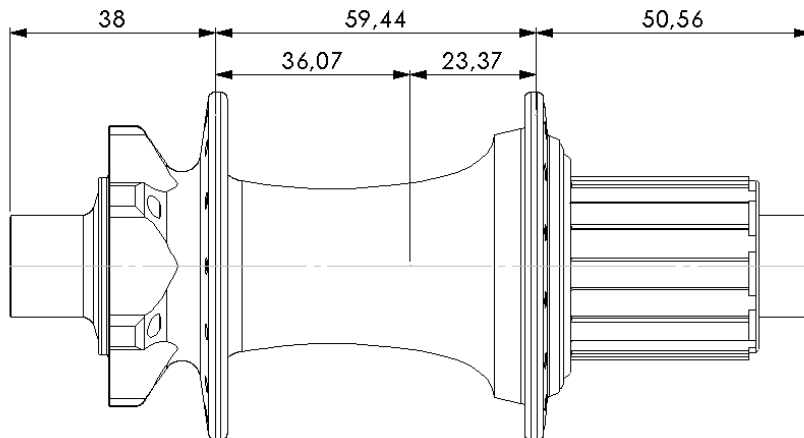

CONVERSION

- Rear hubs are compatible with the XX1 standard via a specific freewheel body kit. It is possible to change the freewheel body by purchasing it separately.

MAINTENANCE

Aivee Edition One MTB are designed to resist. With a little of maintenance, they will be more efficient. When you are accumulating muddy rides, don't hesitate to clean your hub.

Front Hub

To clean the front hub, you must remove easily axle ends and lip seals from the hub. Then, remove the mud and the dust that can bother the bearing functioning. Grease elements and assemble the hub.

Rear Hub

To clean the rear hub, remove an axle end by pulling it. Remove the cassette body by pulling it. Then clean the ratchet and pawls if needed. Lubricate with oil the ratchet and pawls (viscosity: more than 150 cSt), assemble the cassette body into the hub body. Then put axle ends.



SAFETY WARNING

This user manual contains important and useful information regarding the installation, operation and maintenance. Please read it carefully and follow the instruction of installation as detailed in this user guide.

If you have any doubt regarding your ability in installing, please consult your AIVEE dealer and seek the assistance of a professional bicycle mechanic.

Incorrect installation or use may impair performance and could result in a dangerous situation leading to serious injury or death. Components that have experienced excessive wear, deformation, impacts or any other damage, need immediate professional inspection and replacement by a new AIVEE component.

MAINTENANCE

Do not clean your hub with a high-pressure cleaner, this could cause water infiltration and the damaging of some components.

Inspect your AIVEE product before each ride check the dent and its looseness.

Parts after fall or crash should be inspected by professional bicycle mechanic.

WARNING

Continuing to use damaged parts may lead to loss of control and could cause serious injury or death.

Cyclists should inspect their bicycle and parts regularly. He should check bolts and other fasteners periodically for tightness, in order to determine the need for service and to detect any damage that may have occurred from normal use.

For more information, please contact us.

Aivee

Aivee S.A.S

Les Quatre Chemins de l'Oie BP 16-85140 Sainte Florence France

Phone: (33) 2 51 66 10 29 - fax: (33) 2 51 66 08 01

E-mail: contact@Aivee.fr Web: www.Aivee.fr